

■ UMETA HYDRAULIC-TYPE GREASE NIPPLES - SPECIAL DESIGNS

The following types are representing only the most commonly used special-type nipples. For individual applications, UMETA manufactures hydraulic-type grease nipples with special equipment in other versions, with respect to the following:

- dimension
- material
- thread size
- thread form (e. g. with tapered thread)
- length



■ High-pressure hydraulic-type nipple with pin valve



- straight version A/180°
- made of steel, zinc-plated and passivated
- with special pin valve

Technical Details

Due to the special pin valve, the lubrication point will be sealed hermetically after the greasing operation. As a result, internal impulse-like pressures up to 400 bar (5,800 PSI) can be attained, depending on the respective application.

APPLICATION AREA

Central Lubrication systems, Heavy Industry, Heavy Vehicle Industry.

OPERATING INSTRUCTIONS

ATTENTION! During dismantling, utmost caution is required because of the possible pressure load. Dismantling should be done by experienced personnel only!

GW thread
L1 overall length
L2 thread length
SW HEX size

(all measures in mm,
thread metric or in inches)

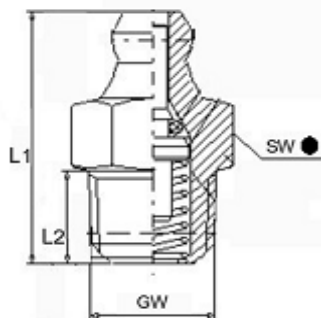

GW	M 10 x 1.0		Ref.- No.:			
L1	L2	SW	Steel	Brass	SST303	SST316L
21	7,5	11mm HEX	5800049			
21	9	11mm HEX	5800052		5800050	

GW		R 1/8, 1/8 - 28 BSP			Ref.- No.:			
L1	L2	SW		Steel	Brass	SST303	SST316L	
21	7,5	11mm HEX	●	5800054		5800051		
21	9	11mm HEX	●	5800053				

GW		G 1/8, 1/8 - 28 BSPP			Ref.- No.:			
L1	L2	SW		Steel	Brass	SST303	SST316L	
21	7	13mm HEX	●	5800056				

GW		G 1/4, 1/4 - 19 BSPP			Ref.- No.:			
L1	L2	SW		Steel	Brass	SST303	SST316L	
21	7	13mm HEX	●			5800057		

GW		1/8" - 27 NPT/PTF			Ref.- No.:			
L1	L2	SW		Steel	Brass	SST303	SST316L	
21	7,5	11mm HEX	●	5800048				
21	9	11mm HEX	●			5800040		

Hydraulic-type nipple, double headed



- made of steel, zinc-plated and passivated
- heads hardened according to DIN
- optionally available as:
 - H2-double head with 67° angle / hexagon body
 - H3-double head with 90° angle / square body

APPLICATION AREA

Option of alternative greasing by means of two heads.

GW thread
L1 overall length
L2 thread length
WL angle length
SW HEX size

(all measures in mm,
thread metric or in inches)

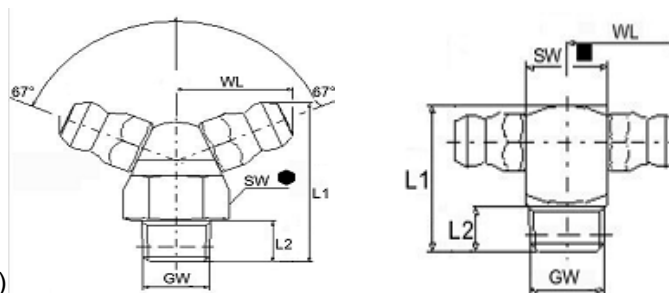

GW		M 6 x 1.0			Ref.- No.:				
L1	L2	WL	W	SW		Steel	Brass	SST303	SST316L
18	5,5	14,5	90°	9mm SQ.	■	5244179			

GW						M 8 x 1.0			
						Ref.- No.:			
L1	L2	WL	W	SW		Steel	Brass	SST303	SST316L
18	5,5	14,5	90°	9mm SQ.	■	5244178			
18	5,5	14,5	90°	11mm SQ.	■	5244181			
20	5,5	13,5	67°	11mm HEX	●	5244159			

GW						M 8 x 1.25			
						Ref.- No.:			
L1	L2	WL	W	SW		Steel	Brass	SST303	SST316L
18	5,5	14,5	90°	9mm SQ.	■	5244096			
20	5,5	13,5	67°	11mm HEX	●	5244160			
24	5,5	14,5	90°	9mm SQ.	■	5244033			

GW						M 10 x 1.0			
						Ref.- No.:			
L1	L2	WL	W	SW		Steel	Brass	SST303	SST316L
18	5,5	15,0	90°	11mm SQ.	■	5244094		5244134	
20	5,5	13,5	67°	11mm HEX	●	5244161			
22	7	13,5	67°	11mm HEX	●	5244163			

GW						R 1/8, 1/8 - 28 BSP			
						Ref.- No.:			
L1	L2	WL	W	SW		Steel	Brass	SST303	SST316L
18	5,5	15,0	90°	11mm SQ.	■	5244095			
20	5,5	13,5	67°	11mm HEX	●	5244162			

Hydraulic-type nipple with extension



- straight version A/180°
- made of steel, zinc-plated and passivated
- head hardened according to DIN
- with tapered thread
- with press-fitted extension for exact grease flow

APPLICATION AREA

For deep seated lubrication points, which can be serviced sufficiently through the extension, e. g. for drive shafts.

GW thread
L1 overall length
L2 installation depth
SW HEX size

(all measures in mm, thread metric or in inches)

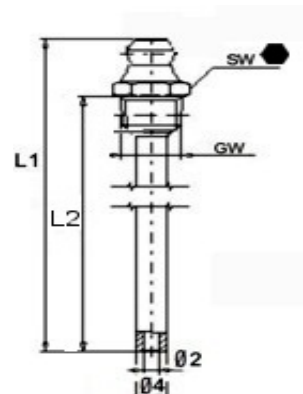

GW		M 8 x 1.0		Ref.- No.:			
L1	L2	SW		Steel	Brass	SST303	SST316L
75	65	9mm HEX	●	5241130			
130	120	9mm HEX	●	5241133			

GW		M 8 x 1.25		Ref.- No.:			
L1	L2	SW		Steel	Brass	SST303	SST316L
32	22	9mm HEX	●	5241213			

GW		M 10 x 1.0		Ref.- No.:			
L1	L2	SW		Steel	Brass	SST303	SST316L
59	49	11mm HEX	●	5241140			
75	65	11mm HEX	●	5241132			

GW		5/16" - 24 NF/UNF/SAE		Ref.- No.:			
L1	L2	SW		Steel	Brass	SST303	SST316L
75	65	9mm HEX	●	5241131			

Hydraulic-type nipple with sealing element



- angled version B/45°
- made of steel, zinc-plated and passivated
- head hardened according to DIN
- with cylindrical thread
- with sintered sealing element under the collar

APPLICATION AREA

Heavy Industry, Heavy Vehicle Industry.

GW thread
L1 overall length
L2 thread length
WL angle length
W angle
SW HEX size

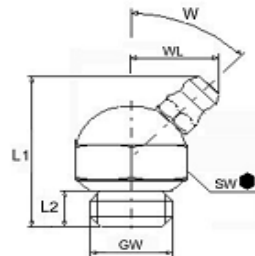

(all measures in mm)

GW		M 14 x 2.0		Ref.- No.:					
L1	L2	WL	W	SW		Steel	Brass	SST303	SST316L
26,6	7	14	45°	19mm HEX	●	5242042			